

XPower Inverter 1000 Plus and 1750 Plus

Owner's Guide

About Xantrex

Xantrex Technology Inc. is a world-leading supplier of advanced power electronics and controls with products from 50 watt mobile units to one MW utility-scale systems for wind, solar, batteries, fuel cells, microturbines, and backup power applications in both grid-connected and stand-alone systems. Xantrex products include inverters, battery chargers, programmable power supplies, and variable speed drives that convert, supply, control, clean, and distribute electrical power.

Trademarks

XPower Inverter 1200 Plus and 1750 Plus is a trademark of Xantrex International. Xantrex is a registered trademark of Xantrex International.

Other trademarks, registered trademarks, and product names are the property of their respective owners and are used herein for identification purposes only.

Notice of Copyright

XPower Inverter 1200 Plus and 1750 Plus Owner's Guide© October 2005 Xantrex International. All rights reserved.

Disclaimer

UNLESS SPECIFICALLY AGREED TO IN WRITING, XANTREX TECHNOLOGY INC.
("XANTREX")

(a) MAKES NO WARRANTY AS TO THE ACCURACY, SUFFICIENCY OR SUITABILITY OF ANY TECHNICAL OR OTHER INFORMATION PROVIDED IN ITS MANUALS OR OTHER DOCUMENTATION.

(b) ASSUMES NO RESPONSIBILITY OR LIABILITY FOR LOSS OR DAMAGE, WHETHER DIRECT, INDIRECT, CONSEQUENTIAL OR INCIDENTAL, WHICH MIGHT ARISE OUT OF THE USE OF SUCH INFORMATION. THE USE OF ANY SUCH INFORMATION WILL BE ENTIRELY AT THE USER'S RISK.

Date and Revision

October 2005 Revision A

Part Number

445-0145-01-01

Contact Information

Telephone: 1 360-925-5059

Fax: 1 360 925 5143

Web: www.xantrex.com/support

About This Guide

Conventions Used

The following conventions are used in this guide.



WARNING

Warnings identify conditions that could result in personal injury or loss of life.



CAUTION

Cautions identify conditions or practices that could result in damage to the XPower Plus or other equipment.

Important: These notes describe an important action item or an item that you must pay attention to.

Note: Notes describe additional information which may add to your understanding of how to use the inverter.

References to XPower Plus

In this guide, both the XPower 1200 Plus and the XPower 1750 Plus are referred to as XPower Plus when the information applies to both models. However, when the information is specific to one model, then reference is made specifically to the XPower 1200 Plus or to the XPower 1750 Plus.

Related Information

You can find more information about Xantrex Technology Inc. as well as its products and services at www.xantrex.com

Important Safety Information

Important: Before installing and using your XPower Plus, be sure to read these safety instructions and keep them handy.



WARNING: Shock hazard

The DC input and AC output of this product are not isolated from each other. Do not operate this unit without a proper chassis ground in accordance with all grounding instructions in this guide.



CAUTION

Do not connect any AC load that has its neutral conductor connected to ground to the XPower Plus.



CAUTION

Do not connect the AC output of this inverter to any other source of power such as an electrical panel which itself may be AC powered from a utility generator or other source. Damage may occur.

General Precautions

1. Before installing and using the inverter, read all appropriate sections of this guide as well as all instructions and cautionary markings on the inverter and the batteries.
2. Do not operate the inverter if it has received a sharp blow, been dropped, or otherwise damaged. If the unit is damaged, see “Warranty” on page WA-1 and “Return Material Authorization Policy” on page WA-3.
3. **Do not disassemble the inverter.** It contains no user-serviceable components. Refer servicing to qualified service personnel only. Attempting to service the unit yourself could cause electrical shock or fire. **Internal capacitors remain charged after all power is disconnected.**
4. To reduce the risk of electrical shock, disconnect AC and DC power from the inverter before working on any circuits connected to the inverter. Turning off the On/Off Switch will not reduce this risk.
5. Do not expose the inverter to rain, snow, spray, or bilge water.
6. To reduce the risk of overheating or fire, do not obstruct the ventilation openings, and do not install the inverter in a zero-clearance compartment.

Explosive Gas Precautions



WARNING: Explosion hazard

1. Batteries generate explosive gases during normal operation. Be sure to read this guide and follow the instructions exactly before installing or using your inverter.
2. This equipment contains components which tend to produce arcs or sparks. To prevent fire or explosion, do not install the inverter in compartments containing batteries or flammable materials or in locations that require ignition-protected equipment. This includes any space containing gasoline-powered machinery, fuel tanks, as well as joints, fittings, or other connections between components of the fuel system.

Precautions When Working With Batteries



WARNING: Explosion and Fire Hazard

1. Follow all instructions published by the battery manufacturer and the manufacturer of the equipment in which the battery is installed.
2. Make sure the area around the battery is well ventilated.
3. Never smoke or allow a spark or flame near the engine or batteries.
4. Use caution to reduce the risk of dropping a metal tool on the battery. It could spark or short circuit the battery or other electrical parts and could cause an explosion.
5. Remove metal items like rings, bracelets, and watches when working with lead-acid batteries. Lead-acid batteries produce a short-circuit current high enough to weld a ring or the like to metal, and thus cause a severe burn.
6. If you need to remove a battery, always remove the ground terminal from the battery first. Make sure all accessories are off so you don't cause a spark.

Precautions For Using Rechargeable Appliances



CAUTION

The output of the inverter is non-sinusoidal.

Most rechargeable battery-operated equipment uses a separate charger or transformer that is plugged into an AC receptacle and produces a low voltage charging output.

Some chargers for small rechargeable batteries can be damaged if connected to the XPower Plus. **Do not use the following with the XPower Plus, overheating may result:**

- Small battery-operated appliances like flashlights, razors, and night lights that can be plugged directly into an AC receptacle to recharge.
- Some chargers for battery packs used in power hand tools. These affected chargers display a warning label stating that dangerous voltages are present at the battery terminals.

Note: If you are unsure about using your rechargeable appliance with the XPower Plus, contact the equipment manufacturer to find out if there are high voltages at the battery terminals or if the appliance incorporates the use of transformers.

Contents

Important Safety Information - - - - -	v
---	---

1 Introduction

Quality Power - - - - -	1-2
Ease of Use - - - - -	1-2
Comprehensive Protection - - - - -	1-3

2 XPower Plus Features

Materials List - - - - -	2-2
Optional Accessory: Remote On/Off Switch - - - - -	2-2
Dimensions of Remote Switch - - - - -	2-2
Part Number of Remote Switch - - - - -	2-2
AC Panel - - - - -	2-3
DC Panel - - - - -	2-4

3 Installation

Designing Your Installation - - - - -	3-2
Installation Codes - - - - -	3-4
Calculating Battery Requirements - - - - -	3-4
Choosing an Effective Charging System - - - - -	3-4
Choosing an Appropriate Location - - - - -	3-5
Calculating Cable Sizes for XPower 1200 Plus - - - - -	3-6
Calculating Cable Sizes for XPower 1750 Plus - - - - -	3-8
Calculating Fuse/Circuit Breaker Size - - - - -	3-10
Installing the XPower Plus - - - - -	3-11
Safety Instructions - - - - -	3-11
Installation Tools and Materials - - - - -	3-11
Overview of Installation Steps - - - - -	3-13
Optional: Installing the Remote On/Off Switch - - - - -	3-13
Mounting the Inverter - - - - -	3-13
Connecting the Chassis Ground - - - - -	3-14
Connecting the DC Cables - - - - -	3-16

4 Operation

Turning the Inverter On and Off	4-2
Operating Several Loads at Once	4-2
Turning the Inverter Off Between Charges	4-2
Input Voltage Display	4-2
Output Power Indicator	4-3
Operating Limits	4-3
Power Output	4-3
Input Voltage	4-4
Inverter Loads	4-4
High Surge Loads	4-4
Trouble Loads	4-5
Connecting Appliances to the XPower Plus	4-6
Routine Maintenance	4-6
Recharging Your Batteries	4-6

5 Troubleshooting

Common Problems	5-2
Buzz in Audio Equipment	5-2
Television Reception	5-2
Troubleshooting Reference	5-3

A Specifications

Electrical Performance	A-2
Physical Specifications	A-2

B Battery Types and Sizes

Battery Types	B-2
Automotive Starting Batteries	B-2
Deep-Cycle Batteries	B-2
Battery Size	B-3
Estimating Battery Requirements	B-4
Battery Sizing Example	B-5
Battery Sizing Worksheet	B-6
Using Multiple Batteries	B-7
Two Batteries Connected In Parallel	B-7
Two Separate Battery Banks	B-7

Battery Tips-----B-8

C Alternators and Charging Systems

Charging System Requirements -----C-2

Charging With an Engine Alternator -----C-2

 Using a Standard Vehicle Alternator -----C-2

 Using an Alternator Controller -----C-3

 Using a High-Output Alternator -----C-3

Charging From AC Power -----C-3

Charging From Alternative Energy Sources -----C-3

Warranty and Return Information -----WA-1

Index 1

1

Introduction

Congratulations on your purchase of the XPower Plus! The XPower Plus inverter has been designed to give you quality power, ease of use, and reliability.

Please take a few moments to read this chapter to familiarize yourself with the main performance features and protection features of the XPower Plus.

Quality Power

The XPower Plus is a quality inverter designed for use in recreational vehicles (RVs), light and heavy duty truck applications, and other in-vehicle applications.

- The XPower 1200 Plus provides up to 1000 watts of continuous power. It is designed to handle loads such as 600 watt microwaves, TVs, VCRs, and midsized power tools.
- The XPower 1750 Plus provides up to 1500 watts of continuous power. It is designed to handle loads such as 1000 watt microwaves, refrigerators, small freezers, circular saws, and small air compressors.
- The inverter's high surge capability lets you handle many hard-to-start loads, including large TVs, refrigerators, and small freezers.
- The unit's low standby battery demand means you don't have to worry about excessive drain on your battery if you leave the inverter on for a few days. When the inverter is on but no power is being supplied to a load, the inverter draws less than 400 mA from the battery.
- The cooling fan in the inverter is thermally activated and comes on when the inverter becomes warm. The fan turns off automatically after the inverter has cooled.

Ease of Use

Superior features and rugged durability have been combined with ease of use:

- The unit is compact, light weight, and easy to install.
- Loads can be powered directly from the AC outlets.
- Easy-to-read indicators on the front panel let you monitor system performance at a glance.
- An optional Remote On/Off Switch lets you control the inverter from a convenient location—up to 20 feet (6 m) away—while the inverter itself is mounted out of sight.

Comprehensive Protection

The XPower Plus is equipped with numerous protection features to guarantee safe and trouble-free operation:

Low battery alarm Alerts you if the battery has become discharged to 11.0 volts or lower.

Low battery voltage shutdown Shuts the inverter down automatically if the battery voltage drops below 10.5 volts. This feature protects the battery from being completely discharged.

High battery voltage shutdown Shuts the inverter down automatically if the input voltage rises to 15 volts or more.

Overload shutdown Shuts the inverter down automatically if a short circuit is detected in the circuitry connected to the inverter's output, or if the loads connected to the inverter exceed the inverter's operating limits.

Over temperature shutdown Shuts the inverter down automatically if its internal temperature rises above an acceptable level.

2

XPower Plus Features

Chapter 2 describes the main features of the XPower Plus. Xantrex recommends that you familiarize yourself with them before installing and operating the inverter.

Materials List

Your XPower Plus package includes:

- One XPower Plus inverter
- Two 5/16 inch lock washers (on the DC input cable terminals)
- Two 5/16 inch nuts (on the DC input cable terminals)
- Owner’s Guide

If any of these materials are missing or are unsatisfactory in any way, please contact your dealer.

As soon as you unpack your inverter, be sure to record the product information in the form, “Information About Your System” on page WA-4.

Optional Accessory: Remote On/Off Switch

An optional Remote On/Off switch can be plugged into the remote switch jack on the bottom of the inverter. The remote switch lets you turn the XPower Plus on and off from a convenient location—up to 20 feet (6 m) away from the inverter.

Dimensions of Remote Switch

Length	2.0 inches (50.5 mm)
Width	2.5 inches (64.0 mm)
Depth	1.0 inches (25.4 mm)
Cable Length	20 feet (6 m)

Part Number of Remote Switch

To purchase a Remote On/Off Switch, please contact Customer Service for a referral to a distributor and provide the part number **808-9500**.

Instructions for installing and using the Remote On/Off Switch are included in the remote switch package.

AC Panel

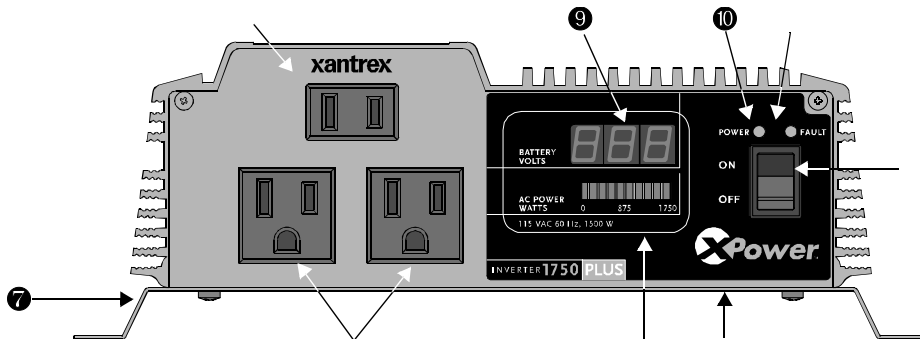

Figure 2-1 AC Panel (XPower 1750 Plus shown)

Feature	Description
1	On/Off Switch turns the inverter's control circuit on and off. This switch is not a power disconnect switch. Disconnect AC and DC power before working on any circuits connected to the inverter.
2	<p>Fault light is a red light indicating the inverter has shut down due to low or high battery voltage, unit overload, or overtemperature.</p> <p>Power light is a green light indicating the On/Off Switch is on and AC voltage is present at the inverter's AC outlets.</p>
3	INPUT VOLTAGE DISPLAY indicates battery voltage.
4	AC Outlets: 2-Prong and 3-Prong XPower 1200 Plus delivers a combined total of 1000 watts of continuous AC power across three outlets. XPower 1750 Plus delivers a combined total of 1500 watts of continuous AC power across three outlets.
5	<p>OUTPUT POWER INDICATOR</p> <ul style="list-style-type: none"> The indicator should be in the green area for continuous operation. If the indicator is in the yellow area, the inverter will operate for several minutes and then shut down. If the indicator is in the red area, the inverter has reached the maximum allowable power and is close to the output power shutdown limit.
6	Remote Switch Jack (not shown) is on the bottom of the inverter, and it is the connection point for the optional Remote On/Off Switch.
7	Mounting Flanges allow you to mount the inverter permanently.

DC Panel

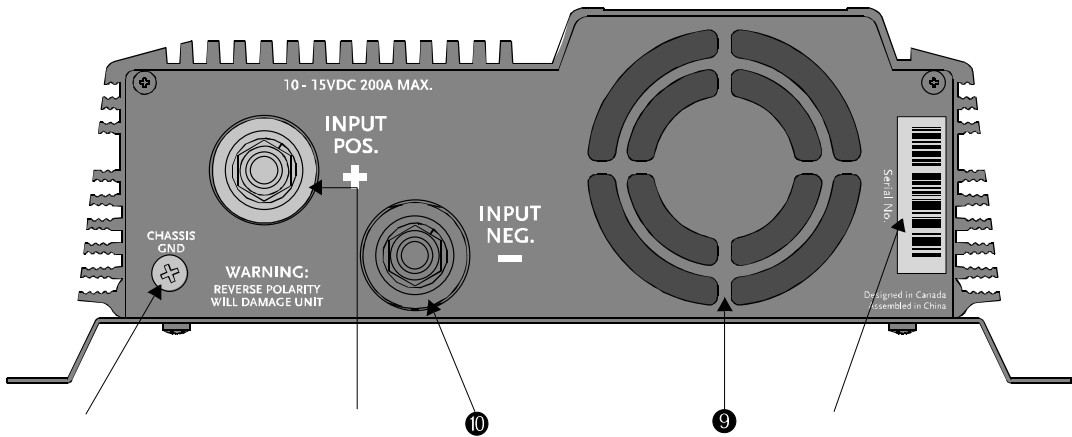

Figure 2-2 DC Panel (XPower 1750 Plus shown)

Feature	Description
1	Chassis Ground Screw connects to vehicle chassis, DC grounding bus or to engine’s negative bus.
2	Positive DC Cabling Terminal always connects to the cable connected to the positive terminal of the battery.
3	Negative DC Cabling Terminal always connects to the cable connected to the negative terminal of the battery.
4	Ventilation Opening must not be obstructed for the proper operation of the inverter. The openings on the bottom of the inverter (not shown) must also not be obstructed. When the inverter is mounted, the ventilation opening on the DC panel must not point up or down.
5	Serial number of your unit

3

Installation

Chapter 3 provides information on cables and fuses to help you plan for your installation and provide procedures for installing the XPower Plus.

Xantrex highly recommends that you read the entire chapter before beginning the installation procedures so that you can plan an installation that is suited to your power needs.

Designing Your Installation

Before doing anything else, you need to determine how you are going to use your XPower Plus, and then design a power system that will give you maximum performance. The more thorough your planning, the better your power needs will be met. In particular, you will need to:

- Be aware of installation codes
- Calculate your battery requirements
- Choose an effective charging system
- Choose an appropriate location
- Calculate the cable size for your XPower 1200 Plus or XPower 1750 Plus
- Select the correct fuses or circuit breakers

Study Figure 3-1, “Configuration for Normal Loads” on page 3–2 and Figure 3-2, “Configuration for Heavy Loads” on page 3–3 for an example of a setup for normal or heavy loads in a vehicle. When you have decided upon your configuration, then you can calculate battery requirements.

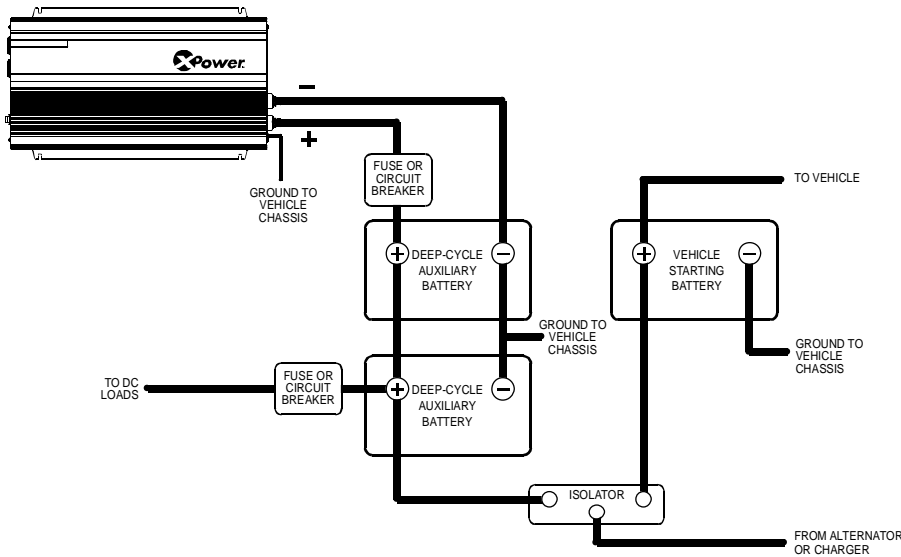

Figure 3-1 Configuration for Normal Loads

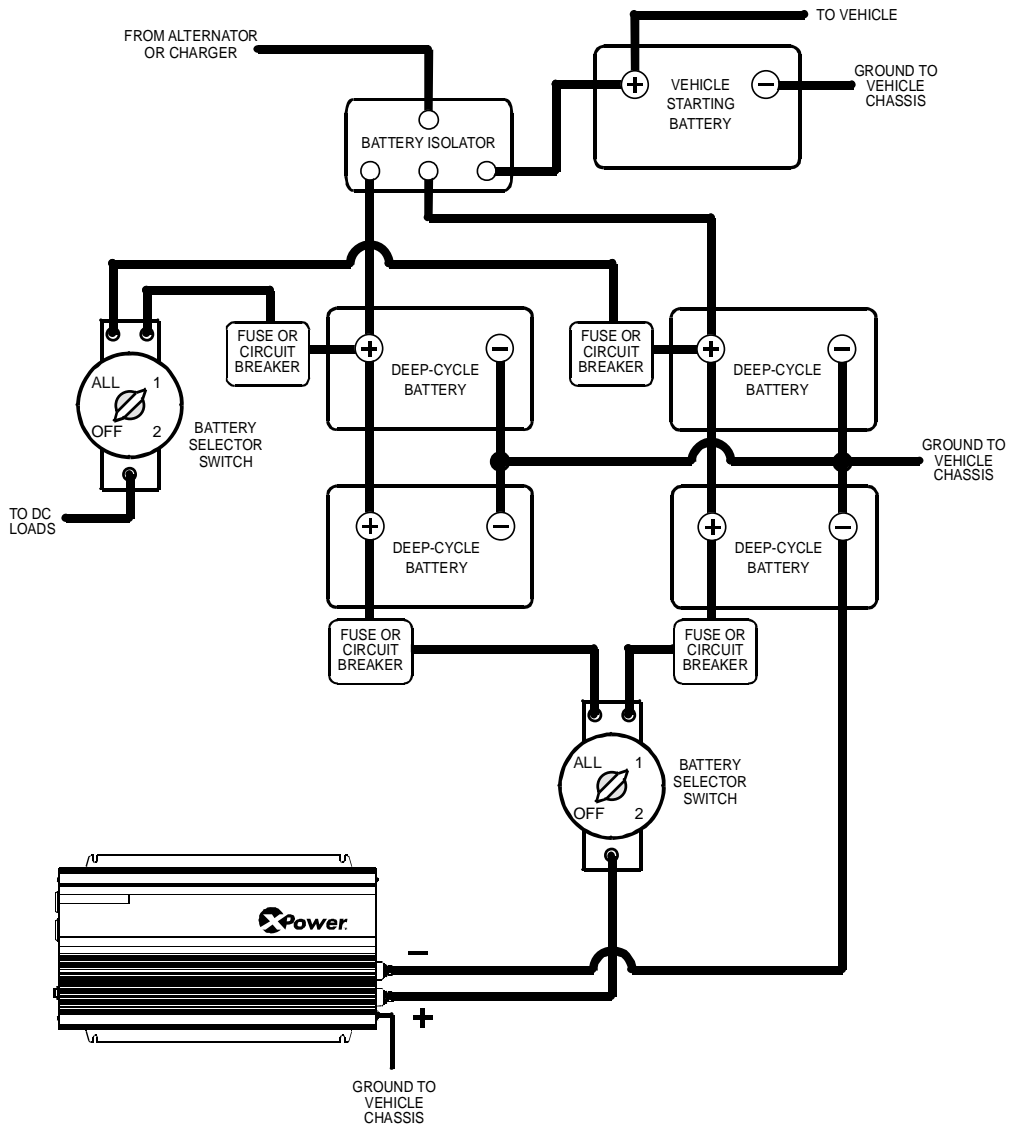

Figure 3-2 Configuration for Heavy Loads

Installation Codes

Governing installation codes vary depending on the location and type of installation. Electrical installations must meet local and national wiring codes and should be performed by a qualified electrician.

In residential applications, electrical codes do not allow permanent connection of AC distribution wiring to the inverter's AC output receptacles. The receptacles are intended for temporary (as-needed) connection of cord connected loads only.

Calculating Battery Requirements

Battery type and battery size strongly affect the performance of the XPower Plus. Therefore, you need to identify the type of loads your inverter will be powering, and how much you will be using them between charges. Once you know how much power you will be using, you can determine how much battery capacity you need. Xantrex recommends that you purchase as much battery capacity as possible.

Consult Appendix B, "Battery Types and Sizes" for a detailed explanation of how to determine the appropriate number and size of batteries for your needs.



CAUTION

The XPower Plus must only be connected to a 12 volt battery system. It will not operate if connected to a 6 volt battery and will be damaged if connected to a 24 volt battery.

Choosing an Effective Charging System

The charging system must be appropriate for your particular installation. A well-designed charging system will ensure that power is available when you need it and that your batteries remain in top condition. Inadequate charging will degrade system performance, and the wrong type of charger will reduce battery life.

Consult Appendix C, "Alternators and Charging Systems" for information about choosing an effective charging system.

Choosing an Appropriate Location



WARNING: Explosion or Fire Hazard

The XPower Plus contains components that tend to produce arcs or sparks. To prevent fire or explosion, do not install the inverter in compartments containing batteries or flammable materials, or in locations that require ignition-protected equipment.



WARNING: Fire Hazard

To reduce the risk of fire, do not cover or obstruct the ventilation openings. Do not install the XPower Plus in a zero-clearance compartment. Overheating may result.

The XPower Plus must only be installed in a location that is:

Dry	Do not allow water or other liquids to drop or splash on it.
Cool	Ambient air temperature should be between 32° F and 105° F (0° C and 40° C)—the cooler the better within this range.
Ventilated	Allow at least 3 inches (76 mm) of clearance around the inverter for air flow. Ensure that the ventilation openings on the DC end and on the bottom of the unit are not obstructed.
Safe	Do not install the inverter in the same compartment as batteries or in any compartment capable of storing flammable liquids like gasoline.
Close to battery	Do not use excessive DC cable lengths: they increase wire resistance and reduce input power. Longer AC wires are preferable to longer DC wires: wire resistance (and therefore voltage drop) is less and the cost is lower.
Protected from battery gases	Do not mount the inverter where it will be exposed to gases produced by batteries. Battery gases are corrosive, and prolonged exposure to battery gases will damage the inverter.

Calculating Cable Sizes for XPower 1200 Plus

To operate safely and effectively, the XPower 1200 Plus needs proper cables and fuses. Because the XPower 1200 Plus has low-voltage and high-current input, it is essential that you use low-resistance wiring between the battery and the inverter to deliver the maximum amount of usable energy to your load.

For safe and efficient operation, you will need to calculate cable sizes for your:

- DC input cables from the battery to inverter (one way)
- Chassis ground cable from the grounding point to the chassis ground screw on the inverter's DC panel.

See Figure 3-3, “DC Panel Connections (XPower 1750 Plus shown)” on page 3-14.



WARNING: Fire Hazard

Never use a cable longer than 5 feet (1.5 meters). A cable longer than 5 feet (1.5 meters) can potentially generate enough heat to start a fire or result in poor inverter performance.

Calculating Size of DC Input Cables for XPower 1200 Plus

Refer to Table 3-1 to plan the DC input cabling for your particular application:

- Keep all cables as short as possible, and ensure that each cable between the inverter and the battery is no longer than 5 feet (1.5 m).
- Do not use aluminum cable. It has about 1/3 more resistance than copper cable of the same size, and it is difficult to make good, low-resistance connections to aluminum wire.
- Xantrex recommends that you use oil resistant cable.

Table 3-1 Recommended DC Input Wire Sizes & Lengths: XPower 1200 Plus

	RV ^a (Recreational Vehicle)	
Cable length: Battery to inverter (one way)	Minimum Cable Size	Maximum Battery Fuse Size
5 feet (1.5 m) or less	No. 2 AWG	150 Adc

Note: Never use a cable longer than 5 feet (1.5 m) with the XPower 1200 Plus. Appropriately sized cable can be bought at a welding supply house or a marine supply store.

- a. Based on US National Electrical Code NFPA70, Article 551 and Table 310-17, 90C cables located outside of engine spaces.

Calculating Size of Chassis Ground Cable for XPower 1200 Plus

Refer to Table 3-2 to plan the size of the chassis ground cable that runs from the grounding point to the chassis ground screw on the inverter’s DC panel.

Table 3-2 Recommended Chassis Ground Cable sizes: XPower 1200 Plus

Application	Chassis ground cable size (Stranded cable is recommended)
Recreational Vehicle ^a	No. 8 AWG

Note: There are no restrictions on length for the chassis ground cable.

- a. Based on US National Electrical Code NFPA70, Article 551, par. 551-20c.

Calculating Cable Sizes for XPower 1750 Plus

To operate safely and effectively, the XPower 1750 Plus needs proper cables and fuses. Because the XPower 1750 Plus has low-voltage and high-current input, it is essential that you use low-resistance wiring between the battery and the inverter to deliver the maximum amount of usable energy to your load.

For safe and efficient operation, you will need to calculate cable sizes for your:

- DC input cables from the battery to inverter (one way)
- Chassis ground cable from the grounding point to the chassis ground screw on the inverter's DC panel.

See Figure 3-3, “DC Panel Connections (XPower 1750 Plus shown)” on page 3-14.



WARNING: Fire Hazard

Never use a cable longer than 6 feet (1.8 meters). A cable longer than 6 feet (1.8 meters) can potentially generate enough heat to start a fire or result in poor inverter performance.

Calculating Size of DC Input Cables for XPower 1750 Plus

Refer to Table 3-3 to plan the DC cabling:

- Keep all cables as short as possible, and ensure that each cable between the inverter and the battery is no longer than 6 feet (1.8 m).
- Do not use aluminum cable. It has about 1/3 more resistance than copper cable of the same size, and it is difficult to make good, low-resistance connections to aluminum wire.
- Xantrex recommends that you use oil resistant cable.

Table 3-3 Recommended DC Input Wire Sizes & Lengths: XPower 1750 Plus

	RV ^a (Recreational Vehicle)	
Cable length: Battery to Inverter (one way)	Minimum Cable Size	Maximum Battery Fuse Size
6 feet (1.8 m) or less	No. 1/0 AWG	250 Adc

Note: Never use a cable longer than 6 feet (1.8 m) with the XPower 1750 Plus. Appropriate size cable can be bought at a welding supply house.

a. Based on US National Electrical Code NFPA70, Article 551 and Table 310-17, 90C cables located outside of engine spaces.

Calculating Size of Chassis Ground Cable for XPower 1750 Plus

Refer to Table 3-4 to plan the size of the chassis ground cable that runs from the DC grounding point to the chassis ground screw on the inverter’s DC panel.

Table 3-4 Recommended Chassis Ground Cable sizes: XPower 1750 Plus

Application	Chassis ground cable size (Stranded cable is recommended)
Recreational Vehicle ^a	No. 8 AWG

Note: There are no restrictions on length for the chassis ground cable.

a. Based on US National Electrical Code NFPA70, Article 551, par. 551-20c.

Calculating Fuse/Circuit Breaker Size

Because your batteries can provide thousands of amps of short-circuit current, you need fuses or circuit breakers that can safely withstand the short-circuit current that the batteries can produce.

To select the correct fuse type and size:

1. Determine the total short-circuit current rating for your batteries. For example:
 - If you are using one battery to power your inverter and its short-circuit current rating is 500 amps, the total short-circuit current rating is 500 amps.
 - If you are powering your inverter with two 12 volt batteries connected in parallel, and each battery has a short-circuit current rating of 500 amps, the total short-circuit current rating is 1000 amps.
 - If you are powering your inverter with two 6 volt batteries connected in series, and each battery has a short-circuit current rating of 500 amps, the total short-circuit current rating is 500 amps.

Note: For batteries connected in parallel, the total short-circuit current rating is the sum of the short-circuit current ratings of all of the batteries connected in parallel. For batteries connected in series, the total short-circuit current rating is equal to the short-circuit rating of a single battery.

2. Once you have determined the total short-circuit current rating of your batteries, pick the fuse/circuit breaker's interrupt capacity based on the short-circuit current calculated in step 1.
3. Pick the fuse/circuit breaker's current rating based on the product used:
 - XPower 1200 Plus: 150 Adc
 - XPower 1750 Plus: 250 Adc

Fuses can be bought at any marine supply store, RV supply store, or electrical products store.

Installing the XPower Plus

Do not proceed with the installation of your XPower Plus until you have read the section, “Designing Your Installation” on page 3–2. The more thorough your planning, the better your power needs will be met to achieve maximum performance from your XPower Plus.

Safety Instructions

Before you start to install the XPower Plus:

- Review the “Important Safety Information” on page v.
- Do not attempt your own AC wiring unless you have the knowledge, tools, and experience to do a safe job. A licensed electrician can install the inverter if you do not wish to do your own wiring.
- Read and follow all Warnings and Cautions in this chapter.

Note: If you have any installation questions or issues, please contact your dealer.

Installation Tools and Materials

Tools

- Wire stripper
- Wrench for DC terminals
- No. 2 Phillips screwdriver
- Crimping tool for fastening lugs and terminals on DC cables. (You may find it more convenient to have the crimp connectors installed onto the DC cable by the store that sells you the cable and/or connectors.)

Materials

The following checklist is a general list of required materials. Optional components are indicated by an *.

- Four corrosion-resistant fasteners sized #10 or larger for mounting the inverter
- Copper DC input cable as calculated in
 - Table 3-1, “ Recommended DC Input Wire Sizes & Lengths: XPower 1200 Plus” on page 3-7
 - Table 3-3, “ Recommended DC Input Wire Sizes & Lengths: XPower 1750 Plus” on page 3-9
- Two 5/16 inch ring terminals sized for the cable diameter (or box-lug terminals) to connect the DC cables to the DC cabling terminal
- Lugs and terminals to connect the DC cables that connect to the battery and fuse holder(s)
- DC fuse(s) as calculated in “Calculating Fuse/Circuit Breaker Size” on page 3-10 and fuse holder(s)
- Copper chassis ground cable as calculated in
 - Table 3-2, “ Recommended Chassis Ground Cable sizes: XPower 1200 Plus” on page 3-7
 - Table 3-4, “ Recommended Chassis Ground Cable sizes: XPower 1750 Plus” on page 3-9
- Ring terminal (appropriately sized to connect copper cable to chassis ground screw) that meets the following specifications:
 - #10 stud
 - UL/CSA approved
 - copper
 - tin-plated
- Battery isolator (if connecting to a multiple-battery system)
- Battery selector switch*
- Alternator controller*
- High-output alternator*

* Consult Appendix B and Appendix C to determine whether you need these components.

Overview of Installation Steps

These are the three steps (and one optional step) for installing your XPower Plus. Do not proceed with installation until you have read “Designing Your Installation” on page 3–2.

1. Optional: Install the Remote On/Off Switch before mounting the inverter as the remote switch connects to a jack on the bottom of the inverter.
2. Mount the inverter.
3. Connect the chassis ground.
4. Connect the DC cables.

Optional: Installing the Remote On/Off Switch

If you are installing the optional Remote On/Off Switch, see the installation instructions in the Remote On/Off Switch package.

Note: Run the cable to the inverter and plug the cable into the remote switch jack on the bottom of the inverter before mounting the inverter. The remote switch jack is not accessible once the inverter is mounted.

Mounting the Inverter

Do not mount the inverter under the hood of your vehicle. See “Choosing an Appropriate Location” on page 3–5.

To mount the XPower Plus:

1. Make sure the On/Off switch is in the Off position.
2. Select an appropriate mounting location and orientation. The XPower Plus must be oriented in one of the following ways:
 - Horizontally on a vertical surface. (Do not mount with the fan pointing up or down.)
 - On or under a horizontal surface
3. Hold the inverter against the mounting surface, mark the positions of the mounting screws, and then remove the inverter.
4. Pilot drill the four mounting holes.
5. Fasten the inverter to the mounting surface using corrosion-resistant fasteners sized #10 or larger.

Connecting the Chassis Ground



WARNING: Electrical Shock Hazard

Never operate the XPower Plus without properly connecting the chassis ground. Electrical shock hazard could result from improper grounding.

The XPower Plus has a screw terminal labelled **CHASSIS GND** on the rear panel as shown in Figure 3-3. Follow the guidelines in “Grounding Locations” to connect the inverter’s chassis to the ground.

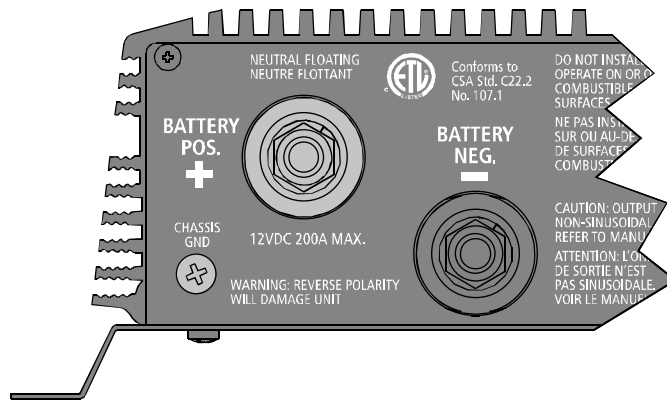

Figure 3-3 DC Panel Connections (XPower 1750 Plus shown)

Grounding Locations

You must connect the chassis ground terminal to a grounding point. The grounding point varies depending on where you install the XPower Plus.

- For recommended chassis ground cable size for the XPower 1200 Plus, see “Calculating Size of Chassis Ground Cable for XPower 1200 Plus” on page 3–7.
- For recommended chassis ground cable size for the XPower 1750 Plus, see “Calculating Size of Chassis Ground Cable for XPower 1750 Plus” on page 3–9.

Follow the instructions that correspond to your type of installation:

To connect the chassis ground terminal to a grounding point:

- ◆ **Recreational Vehicle:** Connect the **CHASSIS GND** screw to the vehicle’s chassis using recommended copper wire (if insulated then green insulation with or without one or more yellow stripes) or larger.

Chassis Ground Screw

Xantrex recommends that you attach the cable to the chassis ground screw with a ring terminal. This procedure will ensure that the wire does not slip off the chassis ground screw.

To connect the cable to the chassis ground screw:

1. Make sure the inverter's On/Off switch is in the Off position.
2. Remove chassis ground screw and star washer using #2 Phillips screwdriver.
3. Strip 1/2 inch (13 mm) to 3/4 inch (19 mm) of insulation from one end of each cable.
4. Attach the ring connector that will join the cable to the chassis ground screw. The connector you use must create a permanent, low-resistance connection. (See "Materials" on page 3–12.)
5. Fit the chassis ground screw through the star washer and the ring connector back into the screw opening.
6. Tighten the chassis ground screw.

Connecting the DC Cables

Consult Figure 3-1, “Configuration for Normal Loads” on page 3–2, or Figure 3-2, “Configuration for Heavy Loads” on page 3–3, for additional details that are specific to your installation.

To connect the DC cables:

1. Make sure the inverter’s On/Off switch is in the Off position.
2. Strip 1/2 inch (13 mm) to 3/4 inch (19 mm) insulation from one end of each cable. The amount stripped off will depend on the terminals chosen.
3. Attach the connectors that will join the cables to the battery, battery isolator switch, or fuse block. The connectors you use must create a permanent, low-resistance connection.

If you are using crimp connectors, use the tool recommended by the terminal manufacturer. Make sure no stray wires protrude from the terminal. (You may find it more convenient to have the crimp connectors attached by the company that sells you the cable and/or connectors.)

4. For each cable end that will be connected to the inverter, strip 1/2 inch (13 mm) to 3/4 inch (19 mm) of insulation from the cable. The amount stripped off will depend on the terminals chosen.
5. Attach the connector that will join the cable to the DC cabling terminal.
6. Install a fuse and fuse holder in the cable that will be used for the positive side of the DC circuit.

The fuse must:

- be as close to the battery as possible
- be rated for DC circuits

7. If you have installed a battery selector switch, set it to Off when making the connection to prevent sparking.
8. Attach the connector on the positive cable to the positive DC terminal on the inverter.
9. Install the lock washer and nut that are supplied with the inverter. Tighten the nut to a torque of **11–13 foot pounds (16–18 Nm)**. Make the connection snug enough so the ring terminal does not move around on the DC terminal, but do not overtighten. See Figure 3-3, “DC Panel Connections (XPower 1750 Plus shown)” on page 3–14.

**CAUTION**

Loose connections cause excessive voltage drop and may cause overheated wires and melted insulation.

**CAUTION**

Do not over tighten the nut on the DC input terminals. Damage to the DC input terminals may result.

The maximum torque setting is **11–13 foot pounds (16–18 Nm)**.

**CAUTION: Reverse Polarity**

DC power connections to the XPower Plus must be positive to positive and negative to negative.

A reverse polarity connection (positive to negative) will blow a fuse in the inverter and may permanently damage the inverter. The fuse is not user replaceable and the inverter may need to be returned for servicing.

Damage caused by a reverse polarity connection is not covered by your warranty.

-
10. Before proceeding, double check that the cable you have just installed connects the positive DC terminal of the inverter to the fuse holder, and that the other end of the fuse holder is connected to the positive terminal on the battery.

**WARNING: Explosion or Fire**

Do not complete the next step if flammable fumes are present. Explosion or fire may result. Thoroughly ventilate the battery compartment before making this connection.

-
11. Connect the cable from the negative post of the battery to the negative DC terminal of the inverter.
 12. Install the lock washer and nut that are supplied. Tighten the nut to a torque of **11–13 foot pounds (16–18 Nm)**. Make the connection snug enough so the ring terminal does not move around on the DC terminal, but do not overtighten.

This the last cable connection. If you do not have a battery selector switch that is between the inverter and batteries, and that is in the Off position, a spark is normal when you make the connection. The connection sequence in Step 12 ensures that the spark happens away from the batteries, reducing the risk of fire or explosion.

13. If you have installed a battery selector switch, use it to select one of the batteries or battery banks (house bank preferred over start bank).
14. Move the inverter's On/Off switch to the On position.

The Power light should come on, indicating that the XPower Plus is ready for operation.

15. Check the **INPUT VOLTAGE DISPLAY**. It should read between 12 and 13 volts, depending on the condition of the battery. If it does not, check your battery and the connection to the inverter, and the state of charge of the battery.

4

Operation

Chapter 4 explains how to operate the XPower Plus efficiently and effectively. Specifically, this chapter:

- Gives procedures for operating the inverter from the front panel
- Discusses operating limits and inverter loads
- Discusses battery charging frequency
- Provides information about routine maintenance

Turning the Inverter On and Off

The On/Off switch on the inverter's front panel turns the control circuit in the XPower Plus on and off.

To turn the inverter on and off from its front panel:

- Move the On/Off switch to the On position to turn the inverter on.
- Move the On/Off switch to the Off position to turn the inverter off.
When the switch is Off, the inverter draws a very low current from the battery.



CAUTION

The XPower Plus's On/Off switch does not disconnect DC battery power from the XPower Plus. You must disconnect AC and DC power before working on any circuits connected to the inverter.

Operating Several Loads at Once

If you are going to operate several loads from the XPower Plus, turn them on separately after you have turned the inverter on.

Turning loads on separately helps to ensure that the inverter does not have to deliver the starting current for all the loads at once, and will help prevent an overload shutdown.

Turning the Inverter Off Between Charges

The XPower Plus draws less than 400 mA from the battery with the On/Off switch turned on and no load connected, but left in this state the XPower Plus will eventually discharge the battery.

To prevent unnecessary battery discharge, turn the XPower Plus off when you are not using it.

Input Voltage Display

The **INPUT VOLTAGE DISPLAY** indicates the DC voltage at the input terminals of the XPower Plus. At low input currents, this voltage is very close to the battery voltage. At high input currents, this voltage is lower than the battery voltage because of the voltage drop across the cable and DC connections.

Output Power Indicator

The **OUTPUT POWER INDICATOR** displays the power that the XPower Plus is delivering to the load. It does not indicate the power drawn by other loads also connected to the battery.

- For long-term continuous operation, the output power indicator should remain in the **green area**, which indicates 80% of maximum allowable power is being consumed.
- Short-term operation is possible with the output power indicator in the **yellow area**, which indicates that 90% or more of the maximum allowable power is being consumed.
- If the output power indicator rises to the **red area**, it indicates that the maximum allowable power output has been reached, and the unit may go into overload shutdown.

Operating Limits

Power Output

The XPower 1200 Plus can deliver up to 1000 watts continuous.

The XPower 1750 Plus can deliver up to 1500 watts continuous.

The wattage rating applies to resistive loads such as incandescent lights.

Input Voltage

The allowable XPower Plus input voltage ranges are shown in the following table:

Operating Condition	Voltage Range	Comment
Normal	10.5 V–15 V	
Optimum Performance	12 V–13 V	
Low Voltage Alarm	11.0 V or less	The audible low battery alarm sounds.
Low Voltage Shutdown	less than 10.5 V	The inverter shuts down to protect the battery from being over-discharged.
High Voltage Shutdown	15 V or more	The inverter shuts down to protect itself from excessive input voltage. Note: Although the XPower Plus incorporates over-voltage protection, it can still be damaged if input voltage exceeds 16 V.

Inverter Loads

The XPower Plus will operate most AC loads within its power rating: 1000 watts for the XPower 1200 Plus and 1500 watts for the XPower 1750 Plus. However, some appliances and equipment may be difficult to operate, and other appliances may actually be damaged if you try to operate them with the XPower Plus. Please read “High Surge Loads” and “Trouble Loads” carefully.

High Surge Loads

Some induction motors used in freezers, pumps, and other motor-operated equipment require high surge currents to start. The XPower Plus may not be able to start some of these motors even though their rated current draw is within the inverter’s limits. The XPower Plus will normally start single-phase induction motors rated at 1/2 horsepower or less.

If a motor refuses to start, observe the **INPUT VOLTAGE DISPLAY** while trying to start the motor. If the indicator drops below 11 volts while the XPower Plus is trying to start the motor, this low voltage condition may be why the motor won't start. Make sure that the battery connections are good and that the battery is fully charged. If the connections are good and the battery is charged, but the voltage still drops below 11 volts, you may need to use a larger battery.

Trouble Loads



CAUTION

Some equipment may be damaged by the XPower Plus's modified sine wave output.

Some appliances, including the types listed below, may be damaged if they are connected to the XPower Plus:

- Electronics that modulate RF (radio frequency) signals on the AC line will not work and may be damaged.
- Speed controllers found in some fans, power tools, kitchen appliances, and other loads may be damaged.
- Some chargers for small rechargeable batteries can be damaged. See "Precautions For Using Rechargeable Appliances" on page viii for details.
- Metal halide arc (HMI) lights can be damaged.

Note: If you are unsure about powering any device with the XPower Plus, contact the manufacturer of the device.

Connecting Appliances to the XPower Plus

Since regular amounts of AC current flows between the XPower Plus and your appliances, commonly available extension cords can be used to connect the XPower Plus to your appliances. If your appliance will be connected at a considerable distance from the XPower Plus, it is much more practical and less expensive to lengthen the AC wiring than it is to lengthen the DC wiring.

Routine Maintenance

Minimal maintenance is required to keep your XPower Plus operating properly. Periodically you should:

- Clean the exterior of the unit with a damp cloth to prevent the accumulation of dust and dirt.
- Ensure that the DC cables are secure and fasteners are tight.
- Make sure ventilation openings on the DC panel and bottom of the inverter are not clogged.

Recharging Your Batteries

When possible, recharge your batteries when they are about 50 percent discharged or earlier. This gives the batteries a much longer life cycle than recharging when they are almost completely discharged. For more information on maintaining batteries, see “Battery Tips” on page B-8.

For information about Xantrex battery chargers, see our web site at **www.xantrex.com**

5

Troubleshooting

Chapter 5 will help you identify the source of most problems that can occur with the XPower Plus.

If you have a problem with the inverter, please review this chapter before contacting your dealer.

If you are unable to solve a problem and need to contact your dealer, record the information in the form “Information About Your System” on page WA-4. This will help our Customer Service Representatives give you better service.

Common Problems

Buzz in Audio Equipment

Some inexpensive stereo systems may emit a buzzing noise from their loudspeakers when operated from the XPower Plus. This occurs because the power supply in the audio system does not adequately filter the modified sine wave produced by the inverter. The only solution is to use a sound system that has a higher quality power supply.

Television Reception

When the XPower Plus is operating, it can interfere with television reception on some channels. If interference occurs, try the following:

1. Make sure that the chassis ground screw on the rear of the XPower Plus is solidly connected to the ground system of your vehicle or home.
2. Make sure that the television antenna provides an adequate (“snow-free”) signal, and that you are using good quality cable between the antenna and the television.
3. Keep the cables between the battery and the XPower Plus as short as possible, and twist them together with two to three twists per foot. (This minimizes radiated interference from the cables.)
4. Move the television as far away from the XPower Plus as possible.
5. Do not operate high power loads with the XPower Plus while the television is on.

Troubleshooting Reference



WARNING: Electrical Shock and Burn Hazard

Do not disassemble the XPower Plus. It does not contain any user-serviceable parts. Attempting to service the unit yourself could result in an electrical shock or burn.

Table 5-1 Troubleshooting Reference

Problem	Possible Cause	Solution
Low output voltage (96 Vac–104 Vac)	You are using a voltmeter that cannot accurately read the RMS voltage of a modified sine wave.	Use a true RMS reading voltmeter such as the Fluke 87.
Low output voltage and the OUTPUT POWER INDICATOR is in the red area.	Low input voltage and the load is close to maximum allowable power.	Check the connections and cable to see if the battery is fully charged. Recharge the battery if it is low. Reduce the load.
No output voltage and the INPUT VOLTAGE DISPLAY indicates below 10.5 volts. Fault LED is on.	Low input voltage	Recharge the battery; check the connections and cable.
No output voltage; no input voltage indication.	The inverter is off. No power to the inverter. Inverter fuse open. The inverter could have been connected with reverse DC input polarity.	Turn the inverter on. Check the wiring to the inverter. Return the unit. Information for returning the inverter is provided in “Return Material Authorization Policy” on page WA-3. The inverter has probably been damaged. Have it repaired. Damage caused by reverse polarity is not covered by the warranty. Information for returning the inverter is provided in “Return Material Authorization Policy” on page WA-3.

A

Specifications

Appendix A contains electrical performance and physical specifications for the XPower Plus.

Electrical Performance

Electrical performance	XPower 1200 Plus	XPower 1750 Plus
Output power at 77° F (25° C) ambient temperature and 12 Vdc input:		
• Maximum continuous output power	1000 W	1500 W
• 5 minute rating	1200 W	1750 W
Output voltage	115 Vac RMS \pm 5 %	115 Vac RMS \pm 5 %
Output waveform	Modified sine wave	Modified sine wave
Output frequency	60 Hz \pm 4 Hz	60 Hz \pm 4 Hz
Input voltage	10–15 Vdc	10–15 Vdc
Low battery alarm	11.0 V	11.0 V
Low battery cutout	10.5 V	10.5 V
Optimum efficiency	90%	90%
No load current draw	<0.4 ADC	<0.4 ADC

Physical Specifications

Physical	XPower 1200 Plus	XPower 1750 Plus
Length	11.4 inches (290 mm)	17.3 inches (440 mm)
Width	9.4 inches (240 mm)	9.4 inches (240 mm)
Height	3.2 inches (83 mm)	3.2 inches (83 mm)
Weight	6.3 lb (2.86 kg)	9.4 lb (4.27 kg)

Specifications are subject to change without notice.

B

Battery Types and Sizes

The batteries that you use strongly affect the performance of the XPower Plus. It is important to connect the inverter to the correct size and type of battery.

The information in Appendix B will help you select, connect, and maintain batteries that are most appropriate for your application.

Battery Types

Automotive Starting Batteries

The lead-acid battery you are most familiar with is probably the starting battery in your vehicle. An automotive starting battery is designed to deliver a large amount of current for a short period of time (so it can start your engine). Only a small portion of the battery's capacity is used when starting the engine, and the spent capacity is quickly recharged by the running engine.

The starting battery in your vehicle is not designed for repeated deep-discharge cycles where the battery is almost completely discharged and then recharged. If a starting battery is used in this kind of deep discharge service, it will wear out very rapidly.

Deep-Cycle Batteries

Deep-cycle batteries are designed for deep discharge service where they will be repeatedly discharged and recharged. They are marketed for use in recreational vehicles, boats, and electric golf carts—so you may see them referred to as RV batteries, marine batteries, or golf cart batteries.

For most applications of the XPower Plus, Xantrex recommends that you use one or more deep-cycle batteries that are separated from the vehicle's starting battery by a battery isolator.

A battery isolator is a solid-state electronic circuit that allows equipment to be operated from an auxiliary battery without danger of discharging the vehicle's starting battery. During vehicle operation, the battery isolator automatically directs the charge from the alternator to the battery requiring the charge. Figure 3-1, "Configuration for Normal Loads" on page 3-2 and Figure 3-2, "Configuration for Heavy Loads" on page 3-3 show a battery isolator in configurations for normal and heavy-duty loads.

Battery isolators are available at marine and RV dealers and most auto parts stores.

Battery Size



CAUTION

The XPower Plus must only be connected to batteries with a nominal output voltage of 12 volts. The XPower Plus will not operate from a 6 volt battery and will be damaged if connected to a 24 volt battery.

Battery size or capacity is as important as the battery type for efficient operation of your loads. Xantrex recommends that you purchase as much battery capacity as possible.

A number of different standards are used to rate battery energy storage capacity. Automotive and marine starting batteries are normally rated in cranking amps. This is not a relevant rating for continuous loads like an inverter. Deep-cycle batteries use a more suitable rating system, either “amp-hours” (“Ah”) or “reserve capacity” in minutes.

Battery Reserve Capacity Battery reserve capacity is a measure of how long a battery can deliver a certain amount of current—usually 25 amps. For example, a battery with a reserve capacity of 180 minutes can deliver 25 amps for 180 minutes before it is completely discharged.

Amp-hour (Ah) Capacity Amp-hour capacity is a measure of how many amps a battery can deliver for a specified length of time—usually 20 hours. For example, a typical marine or RV battery rated for 100 Ah can deliver 5 amps for 20 hours ($5 \text{ A} \times 20 \text{ hours} = 100 \text{ Ah}$).

This same battery can deliver a higher or lower current for less or more time, limited approximately by the 100 Ah figure (for example, 50 A for 2 hours, or 200 A for 1/2 hour), but usually the capacity figure given is only accurate at the specified rate (20 hours).

To calculate the battery capacity you require, read “Estimating Battery Requirements” on page B-4 and “Battery Sizing Example” on page B-5, and then complete the “Battery Sizing Worksheet” on page B-6.

Estimating Battery Requirements

To determine how much battery capacity you need:

1. Determine how many watts are consumed by each appliance that you will operate from the XPower Plus. You can normally find the watt rating labelled on the product. If only the current draw is given, multiply it by 115 to get the power consumption in watts.
2. Estimate how many hours each appliance will be operating each day.
3. Calculate the daily watt-hours needed for each appliance.
4. Add the total number of watt-hours needed for all the appliances and multiply it by the number of days between charges.
5. Divide the total watt-hours of AC load between charges by 10. This gives the battery Ah used between charges.
6. Double the total Ah used between charges to get the recommended battery size in Ah.

See the battery sizing example that follows.

Battery Sizing Example

This battery sizing example illustrates a typical calculation, assuming an opportunity to charge the batteries every three days.

Appliance	(A) Power Consumption (Watts)	(B) Operating Time per Day (Hours)	Daily watt-hours needed for this appliance (= A x B)
TV & VCR	200 W	2 hours	400 Wh
Microwave oven	1400 W	15 min = 1/4 hour	350 Wh
3 lamps, 60 W each	180 W	4 hours	720 Wh
Coffee maker	600 W	15 min = 1/4 hour	150 Wh
Hair dryer	1500 W	6 min = 1/10 hour	150 Wh
Steam iron	700 W	6 min = 1/10 hour	70 Wh
Total daily watt-hours of AC load			1840 Wh
x Number of days between charges			3
= Total watt-hours of AC load between charges			5520 Wh
Battery Ah used between charges (divide by 10)			552 Ah
Recommended Battery Bank Size in Ah (multiply by 2)			1104 Ah

This example illustrates how quickly your battery needs can escalate. To reduce the required battery size, you can conserve energy by eliminating or reducing the use of some loads or by re-charging more frequently.

When sizing your battery, resist the temptation to skip the last step of this calculation (multiplying by 2). More capacity is better since you will have more reserve capacity, be better able to handle large loads and surge loads, and your battery won't be discharged as deeply. Battery life is directly dependent on how deeply the battery is discharged. The deeper the discharge, the shorter the battery life.

Battery Sizing Worksheet

Use the following worksheet to calculate your battery needs. To ensure sufficient battery capacity, be generous when estimating the operating time per day for each of the loads you will run.

Appliance	(A) Power Consumption (Watts)	(B) Operating Time per day (Hours)	Daily watt-hours needed for this appliance (= A x B)
	W	hours	Wh
	W	hours	Wh
	W	hours	Wh
	W	hours	Wh
	W	hours	Wh
	W	hours	Wh
	W	hours	Wh
	W	hours	Wh
Total daily watt-hours of AC load			Wh
x Number of days between charges			
= Total watt-hours of AC load between charges			Wh
Battery Ah used between charges (divide by 10)			Ah
Recommended Battery Bank Size in Ah (multiply by 2)			Ah

Using Multiple Batteries

As your power requirements increase, you may need to use more than one battery to obtain sufficient capacity. Read “Two Batteries Connected In Parallel” and “Two Separate Battery Banks” to determine whether two batteries or two battery banks are more appropriate for your applications.

Two Batteries Connected In Parallel

Two identical batteries can be connected positive (+) to positive (+) and negative (–) to negative (–) in a parallel system. A parallel system doubles capacity and maintains the voltage of a single battery.

Figure 3-1, “Configuration for Normal Loads” on page 3–2 shows a battery configuration suitable for normal loads.

Figure 3-2, “Configuration for Heavy Loads” on page 3–3 show a battery configuration that is recommended for heavy loads.



CAUTION

Do not connect the following in parallel:

- batteries made by different manufacturers
- different types of batteries
- batteries that have different Ah ratings

Decreased battery life and improper charging will result.

Two Separate Battery Banks

If you need more than two batteries (or are using different makes or models of batteries), Xantrex recommends that you install two separate battery banks and a battery selector switch.

Figure 3-2, “Configuration for Heavy Loads” on page 3–3 shows two separate battery banks and a battery selector switch. This configuration is recommended for heavy-duty applications.

By installing a battery selector switch, you can select between the two battery banks, use both banks in parallel, or disconnect both banks from the load. Battery selector switches are available at marine and RV dealers.

Battery Tips



WARNING

Review “Precautions When Working With Batteries” on page vii before you work with the batteries in your system.

Explosive/Corrosive Gases Lead-acid batteries may emit hydrogen gases, oxygen, and sulfuric acid fumes when recharging. To reduce the risk of explosion:

- Vent the battery compartment to prevent the accumulation of gases.
- Do not install electronic or electrical equipment in the battery compartment.
- Do not smoke or use an open flame when working around batteries.

Temperature Sensitivity The capacity of lead-acid batteries is temperature sensitive. Battery capacity is rated at 77° F (25° C). At 0° F (–20° C), the Ah capacity is about half the rated capacity. You should consider temperature when designing your system.

- **Low Temperatures** If extremely low temperatures are expected where the inverter is going to be located, you should consider a heated equipment room. If the system is located in an unheated space, an insulated battery enclosure is recommended.
- **High Temperatures** The batteries should also be protected from high temperatures. These can be caused by high ambient temperatures, solar heating of the battery enclosure, or heat released by a nearby engine or generator. High battery temperatures shorten battery life and therefore you should ventilate the enclosure and use shade and insulation as appropriate.

Discharged Batteries Do not leave batteries in a discharged state for more than a day or two. They will undergo a chemical process (sulfation) that can permanently damage the battery. As well, batteries self-discharge over a period of three to six months, and they should be recharged periodically even if they are not being used.

Electrolyte Level If your batteries are not the “maintenance-free” type, check the electrolyte level at least once a month. Excessive fluid loss is a sign of overcharging. Replenish the electrolyte using only distilled water.

Battery Connections Connections to battery posts must be made with permanent connectors that provide a reliable, low-resistance connection. Do not use alligator clips. Clean the connections regularly and prevent corrosion by using a protective spray coating or Vaseline.

Battery State of Charge You can measure battery state of charge with a hydrometer or approximate state of charge with a voltmeter. Use a digital voltmeter that can display tenths or hundredths of a volt when measuring 10 to 30 volts. Make your measurements when the battery has not been charged or discharged for several hours. For a deep-cycle battery at 77° F (25° C), use the following table:

Battery Voltage	State of Charge
12.7–13.0	100%
12.5–12.6	80%
12.3–12.4	60%
12.1–12.2	40%
11.9–12.0	20%

C

Alternators and Charging Systems

A good charging system is important for the health of your batteries. Poor recharging methods can quickly damage batteries.

Appendix C provides guidelines for recharging batteries from an alternator, from AC power, and from alternate energy sources.

Charging System Requirements

Your charging system should be capable of delivering a charging current equal to 25% of the amp-hour capacity of your battery. For example, if you have a 200 Ah battery, the charging system should be able to deliver 50 amps. The charging system must also be able to charge each 12 volt battery up to approximately 14.4 V and then drop back to a “float” voltage of 13.5–14 V (or shut off).



CAUTION

Never operate the XPower Plus directly from an alternator. To work properly, the inverter must be connected to a battery or a well-regulated, high-current DC power supply.

Charging With an Engine Alternator

Read the following information to determine whether your vehicle’s standard alternator will be adequate by itself, whether you should install an alternator controller, or whether you need a high-output alternator.

Using a Standard Vehicle Alternator

A typical engine alternator (12 volts) may not be able to meet the requirements outlined above if your system uses large capacity batteries. Alternators are typically rated for the current they can deliver when they are cold. When in use, alternators heat up, and their output current capability drops by as much as 25%. Therefore, standard alternators with ratings of 40–105 amps only deliver a maximum of 30–80 amps in actual use and deliver even less as battery voltage rises. Many alternators cannot produce more than 13.6 volts when they are hot. As a result, a standard alternator may not be able to charge a large battery quickly and completely.

Two solutions are to install an alternator controller or to install a high-output alternator.

Using an Alternator Controller

If your regular alternator is inadequate, you can install an alternator controller that bypasses the voltage regulator and boosts the alternator's output voltage during charging. This will increase the alternator's charging rate at higher battery voltages and ensure more rapid and complete charging.

Using a High-Output Alternator

Heavy-duty alternators rated from 100–140 amps can replace standard alternators and produce the higher current and voltage required to charge multiple battery systems. They are available from RV and auto parts suppliers.

Charging From AC Power

When recharging from AC power, use a good quality charger or RV converter that meets the requirements outlined in “Charging System Requirements” on page C–2.

For information about Xantrex's battery chargers, visit our web site at **www.xantrex.com**.

Do not use chargers intended for occasional recharging of automotive starting batteries. These chargers are not intended for continuous use.

Charging From Alternative Energy Sources

You can also charge your batteries from alternative energy sources such as solar panels, wind, or hydro systems. Make sure you use the appropriate battery charge controller for your particular energy source.



CAUTION

Never operate the XPower Plus directly from an energy source such as a solar panel. The inverter must be connected to a battery or a well-regulated, high-current DC power supply to work properly.

Warranty and Return Information

Warranty

What does this warranty cover? This Limited Warranty is provided by Xantrex Technology Inc. ("Xantrex") and covers defects in workmanship and materials in your XPower Inverter 1200 Plus and 1750 Plus. This warranty period lasts for twelve (12) months from the date of purchase at the point of sale to you, the original end user customer. You require proof of purchase to make warranty claims.

What will Xantrex do? Xantrex will, at its option, repair or replace the defective product free of charge, provided that you notify Xantrex of the product defect within the Warranty Period, and provided that Xantrex through inspection establishes the existence of such a defect and that it is covered by this Limited Warranty.

Xantrex will, at its option, use new and/or reconditioned parts in performing warranty repair and building replacement products. Xantrex reserves the right to use parts or products of original or improved design in the repair or replacement. If Xantrex repairs or replaces a product, its warranty continues for the remaining portion of the original Warranty Period or 90 days from the date of the return shipment to the customer, whichever is greater. All replaced products and all parts removed from repaired products become the property of Xantrex.

Xantrex covers both parts and labor necessary to repair the product, and return shipment to the customer via a Xantrex-selected non-expedited surface freight within the contiguous United States and Canada. Alaska and Hawaii are excluded. Contact Xantrex Customer Service for details on freight policy for return shipments outside of the contiguous United States and Canada.

How do you get service?

If your product requires troubleshooting or warranty service, contact your dealer.

If you are unable to contact your dealer, or the dealer is unable to provide service, contact Xantrex directly at:

Phone: 1 360-925-5059

Fax: 1 360-925-5143

Website: www.xantrex.com/support

Direct returns may be performed according to the Xantrex Return Material Authorization Policy described in your product manual. For some products, Xantrex maintains a network of regional Authorized Service Centers. Call Xantrex or check our website to see if your product can be repaired at one of these facilities.

What proof of purchase is required? In any warranty claim, dated proof of purchase must accompany the product and the product must not have been disassembled or modified without prior written authorization by Xantrex.

Proof of purchase may be in any one of the following forms:

- The dated purchase receipt from the original purchase of the product at point of sale to the end user, or
- The dated dealer invoice or purchase receipt showing original equipment manufacturer (OEM) status, or
- The dated invoice or purchase receipt showing the product exchanged under warranty

What does this warranty not cover? This Limited Warranty does not cover normal wear and tear of the product or costs related to the removal, installation, or troubleshooting of the customer's electrical systems. This warranty does not apply to and Xantrex will not be responsible for any defect in or damage to:

- a) the product if it has been misused, neglected, improperly installed, physically damaged or altered, either internally or externally, or damaged from improper use or use in an unsuitable environment;
- b) the product if it has been subjected to fire, water, generalized corrosion, biological infestations, or input voltage that creates operating conditions beyond the maximum or minimum limits listed in the Xantrex product specifications including high input voltage from generators and lightning strikes;
- c) the product if repairs have been done to it other than by Xantrex or its authorized service centers (hereafter "ASCs");
- d) the product if it is used as a component part of a product expressly warranted by another manufacturer;
- e) the product if its original identification (trade-mark, serial number) markings have been defaced, altered, or removed.

Disclaimer

Product

THIS LIMITED WARRANTY IS THE SOLE AND EXCLUSIVE WARRANTY PROVIDED BY XANTREX IN CONNECTION WITH YOUR XANTREX PRODUCT AND IS, WHERE PERMITTED BY LAW, IN LIEU OF ALL OTHER WARRANTIES, CONDITIONS, GUARANTEES, REPRESENTATIONS, OBLIGATIONS AND LIABILITIES, EXPRESS OR IMPLIED, STATUTORY OR OTHERWISE IN CONNECTION WITH THE PRODUCT, HOWEVER ARISING (WHETHER BY CONTRACT, TORT, NEGLIGENCE, PRINCIPLES OF MANUFACTURER'S LIABILITY, OPERATION OF LAW, CONDUCT, STATEMENT OR OTHERWISE), INCLUDING WITHOUT RESTRICTION ANY IMPLIED WARRANTY OR CONDITION OF QUALITY, MERCHANTABILITY OR FITNESS FOR A PARTICULAR PURPOSE. ANY IMPLIED WARRANTY OF MERCHANTABILITY OR FITNESS FOR A PARTICULAR PURPOSE TO THE EXTENT REQUIRED UNDER APPLICABLE LAW TO APPLY TO THE PRODUCT SHALL BE LIMITED IN DURATION TO THE PERIOD STIPULATED UNDER THIS LIMITED WARRANTY.

IN NO EVENT WILL XANTREX BE LIABLE FOR ANY SPECIAL, INDIRECT, INCIDENTAL OR CONSEQUENTIAL DAMAGES, LOSSES, COSTS OR EXPENSES HOWEVER ARISING WHETHER IN CONTRACT OR TORT INCLUDING WITHOUT RESTRICTION ANY ECONOMIC LOSSES OF ANY KIND, ANY LOSS OR DAMAGE TO PROPERTY, ANY PERSONAL INJURY, ANY DAMAGE OR INJURY ARISING FROM OR AS A RESULT OF MISUSE OR ABUSE, OR THE INCORRECT INSTALLATION, INTEGRATION OR OPERATION OF THE PRODUCT.

Exclusions

If this product is a consumer product, federal law does not allow an exclusion of implied warranties. To the extent you are entitled to implied warranties under federal law, to the extent permitted by applicable law they are limited to the duration of this Limited Warranty. Some states and provinces do not allow limitations or exclusions on implied warranties or on the duration of an implied warranty or on the limitation or exclusion of incidental or consequential damages, so the above limitation(s) or exclusion(s) may not apply to you. This Limited Warranty gives you specific legal rights. You may have other rights which may vary from state to state or province to province.

Warning: Limitations On Use

Please refer to your product manual for limitations on uses of the product.

SPECIFICALLY, PLEASE NOTE THAT THE XPOWER INVERTER 1200 PLUS AND 1750 PLUS SHOULD NOT BE USED IN CONNECTION WITH LIFE SUPPORT SYSTEMS OR OTHER MEDICAL EQUIPMENT OR DEVICES.

WITHOUT LIMITING THE GENERALITY OF THE FOREGOING, XANTREX MAKES NO REPRESENTATIONS OR WARRANTIES REGARDING THE USE OF THE XANTREX XPOWER INVERTER 1200 PLUS AND 1750 PLUS IN CONNECTION WITH LIFE SUPPORT SYSTEMS OR OTHER MEDICAL EQUIPMENT OR DEVICES.

Please note that the XPower Inverter 1200 Plus and 1750 Plus is not intended for use as an uninterruptible power supply and Xantrex makes no warranty or representation in connection with any use of the product for such purposes.

Return Material Authorization Policy

Before returning a product directly to Xantrex you must obtain a Return Material Authorization (RMA) number and the correct factory "Ship To" address. Products must also be shipped prepaid. Product shipments will be refused and returned at your expense if they are unauthorized, returned without an RMA number clearly marked on the outside of the shipping box, if they are shipped collect, or if they are shipped to the wrong location.

When you contact Xantrex to obtain service, please have your instruction manual ready for reference and be prepared to supply:

- The serial number of your product
- Information about the installation and use of the unit
- Information about the failure and/or reason for the return
- A copy of your dated proof of purchase

Record these details in "Information About Your System" on page WA-4.

Return Procedure

1. Package the unit safely, preferably using the original box and packing materials. Please ensure that your product is shipped fully insured in the original packaging or equivalent. This warranty will not apply where the product is damaged due to improper packaging.
2. Include the following:
 - The RMA number supplied by Xantrex Technology Inc. clearly marked on the outside of the box.
 - A return address where the unit can be shipped. Post office boxes are not acceptable.
 - A contact telephone number where you can be reached during work hours.
 - A brief description of the problem.
3. Ship the unit prepaid to the address provided by your Xantrex customer service representative.

If you are returning a product from outside of the USA or Canada In addition to the above, you MUST include return freight funds and are fully responsible for all documents, duties, tariffs, and deposits.

If you are returning a product to a Xantrex Authorized Service Center (ASC) A Xantrex return material authorization (RMA) number is not required. However, you must contact the ASC prior to returning the product or presenting the unit to verify any return procedures that may apply to that particular facility.

Out of Warranty Service

If the warranty period for your XPower Inverter 1200 Plus and 1750 Plus has expired, if the unit was damaged by misuse or incorrect installation, if other conditions of the warranty have not been met, or if no dated proof of purchase is available, your unit may be serviced or replaced for a flat fee.

To return your XPower Inverter 1200 Plus and 1750 Plus for out of warranty service, contact Xantrex Customer Service for a Return Material Authorization (RMA) number and follow the other steps outlined in “Return Procedure” on page WA-3.

Payment options such as credit card or money order will be explained by the Customer Service Representative. In cases where the minimum flat fee does not apply, as with incomplete units or units with excessive damage, an additional fee will be charged. If applicable, you will be contacted by Customer Service once your unit has been received.

Information About Your System

As soon as you open your XPower Inverter 1200 Plus and 1750 Plus package, record the following information and be sure to keep your proof of purchase.

- Serial Number (on DC end) _____
- Purchased From _____
- Purchase Date _____

If you need to contact Customer Service, please record the following details before calling. This information will help our representatives give you better service.

- Type of installation (e.g. RV, truck) _____
- Length of time inverter has been installed _____
- Battery/battery bank size _____
- Battery type (e.g. flooded, sealed gel cell, AGM) _____
- DC wiring size and length _____
- Alarm sounding? _____
- Description of indicators on front panel _____
- Appliances operating when problem occurred _____
- Description of problem _____

Index

A

AC panel illustrated 2–3
Ah
 See amp-hour capacity
alarm, low battery 1–3, 4–4, 5–4
alternator
 high-output 3–12, C–3
 vehicle alternator C–2
alternator controller 3–12
 described C–3
 installing C–3
amp-hour (Ah) capacity B–3
appliances
 battery-operated 1–viii
 current draw B–4
 fans 4–5
 possible damage to 4–5
 power consumption B–4, B–6
 rechargeable 1–viii
 televisions 1–2
 VCRs 1–2

B

batteries
 amp-hour (Ah) capacity B–3
 automotive starting B–2, B–3
 connecting two in parallel B–7
 deep-cycle lead-acid B–2
 depth of discharge B–5
 discharged B–8
 electrolyte level B–8
 golf cart B–2
 marine B–2
 rechargeable 1–viii, 4–5
 recharging 4–6
 reserve capacity B–3, B–5
 routine maintenance 4–6
 RV B–2
 self-discharge B–8
 temperature sensitivity B–8
 using multiple B–7
 using two battery banks B–7
battery banks, described B–7
battery chargers 4–6
 for rechargeable batteries 1–viii
 recommended types C–3
battery connections B–9
battery demand, standby 1–2, A–2
battery isolator
 component 3–12
 using B–2
battery reserve capacity B–3
battery selector switch 3–18, B–7
battery size
 estimating example B–5
 estimating worksheet B–6
 estimating your needs 3–4, B–3, B–4
battery tips B–8
battery voltage 2–3
buzz in audio equipment 5–2

C

- cable sizes
 - calculating for XPower 1200 Plus 3-6
 - calculating for XPower 1750 Plus 3-8
- cabling
 - configuration for heavy loads illustrated 3-3
 - configuration for normal loads illustrated 3-2
- charging
 - from AC power C-3
 - from alternative energy sources C-3
 - using a high-output alternator C-3
 - using an alternator controller C-3
 - with engine alternator C-2
- charging systems
 - designing a system 3-4, C-2
 - requirements C-2
- chassis ground
 - for recreational vehicles 3-14
 - guidelines for connecting 3-14
- chassis ground cable sizes
 - XPower 1200 Plus 3-7
 - XPower 1750 Plus 3-9
- chassis ground screw 2-4, 3-14
- current draw, no load 1-2, A-2
- Customer Service
 - preparing to call WA-4

D

- DC cables
 - avoiding excessive lengths 3-5
 - correct polarity 3-17
- DC cabling terminals 2-4
- DC input wire sizes and lengths for XPower 1200 Plus 3-6
- DC input wire sizes and lengths for XPower 1750 Plus 3-8
- DC panel connections illustrated 3-14
- DC panel illustrated 2-4
- depth of discharge (DOD) B-5

E

- electrolyte level B-8
- explosive gases 1-vii, 3-17, B-8

F

- Fault light 2-3
 - for 3-8
- freezers 4-4
- fuses 3-10, 3-12
 - type and size 3-10

G

- gases
 - battery, venting 3-5
 - explosive 1-vii, 3-17, B-8

H

- high-output alternator
 - described C-3
 - installing C-3
 - mention 3-12
- hydrometer B-9

I

- Information about Your System form WA-4
- input voltage 4-4
- Input Voltage Display 2-3, 4-2, 5-3
- installation
 - codes 3-4
 - overview of steps 3-13
- installation materials 3-12
- installation tools 3-11
- installation, designing your 3-2
- inverter
 - back panel features described 2-4
 - electrical specifications A-2
 - front panel features described 2-3
 - front panel illustrated 2-3
 - input voltage 4-4
 - loads 4-4
 - mounting location 3-5, 3-13
 - mounting orientation 3-13
 - operating several loads 4-2
 - physical specifications A-2
 - power output 4-3
 - problem loads 4-4

- purchase date WA-4
- serial number WA-4
- trouble loads 4-5
- turning off between charges 4-2
- turning on and off 4-2

J

- jack
 - to connect remote On/Off switch 2-3

L

- loads
 - chargers 4-5
 - electronics 4-5
 - fans 4-5
 - power tools 4-5
 - resistive 4-3
 - speed controllers 4-5
 - trouble 4-5
- low battery alarm 4-4, 5-4

M

- materials list for XPower Plus 2-2
- metal halide arc lights, damage to 4-5
- motors
 - difficulty starting 4-5
 - induction 4-4
- mounting flanges 2-3
- mounting location 3-5
- mounting orientation 3-13

O

- On/Off switch (front panel)
 - illustration and description 2-3
 - using 4-2
- Output Power Indicator 2-3, 4-3, 5-3
- output voltage low 5-3

P

- power light 2-3
- power output 4-3

- power tools 1-2
- power tools, battery-operated 1-viii
- precautions
 - explosive gas 1-vii
 - when using rechargeable appliances 1-viii
 - when working with batteries 1-vii
- product information, recording 2-2
- proof of purchase WA-4
- pumps 4-4
- purchase date WA-4

R

- recommended chassis ground cable sizes
 - XPower 1200 Plus 3-7
 - XPower 1750 Plus 3-9
- recommended DC input wire sizes & lengths for XPower 1750 Plus 3-9
- recommended DC input wires sizes & lengths for XPower 1200 Plus 3-7
- remote on/off switch
 - dimensions 2-2
 - optional accessory 2-2
 - part number 2-2
 - purchasing 2-2
- remote switch jack 2-3
- reserve capacity B-3
- residential 3-4
- reverse polarity, damage caused by 3-17
- ring terminal
 - chassis ground screw 3-12
 - DC input cables 3-12
- routine maintenance 4-6

S

- safety information 1-v, 3-11
- serial number 2-4, WA-4
- servicing
 - no user-serviceable parts 1-vi, 5-3
 - qualified service personnel only 1-vi
- shutdown
 - from AC overload 1-3
 - from high or low battery voltage 1-3
 - from high temperature 1-3

Index

specifications
 inverter A-2
starting batteries B-3
state of charge B-9

T

television reception 5-2
televisions 1-2
temperature
 ideal ambient 3-5
troubleshooting
 buzz in audio equipment 5-2
 common problems 5-2
 reference table 5-3
 television reception 5-2

U

US National Electrical Code 3-7, 3-9

V

VCRs 1-2
ventilation 1-vi, 1-vii, 3-5, B-8
ventilation openings 2-4
voltmeter B-9

W

warranty
 damage caused by reverse polarity 3-17
 out of warranty service WA-4
 terms and conditions WA-1
web site 1-iii

X

Xantrex
 web site 1-iii
XPower 1200 Plus 3-6
XPower 1750 Plus 3-8